

4

3

2

1

| REVISIONS (INDICATED BY ▲) | | | |
|----------------------------|------|------|-------|
| REV | DATE | DDR# | TITLE |
| | | | |

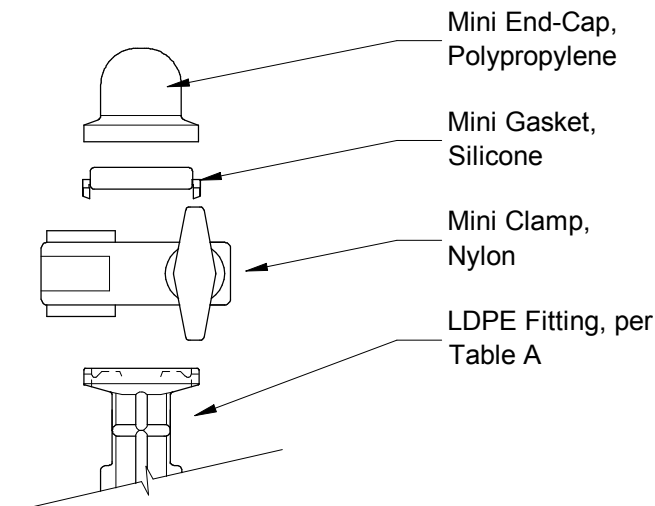
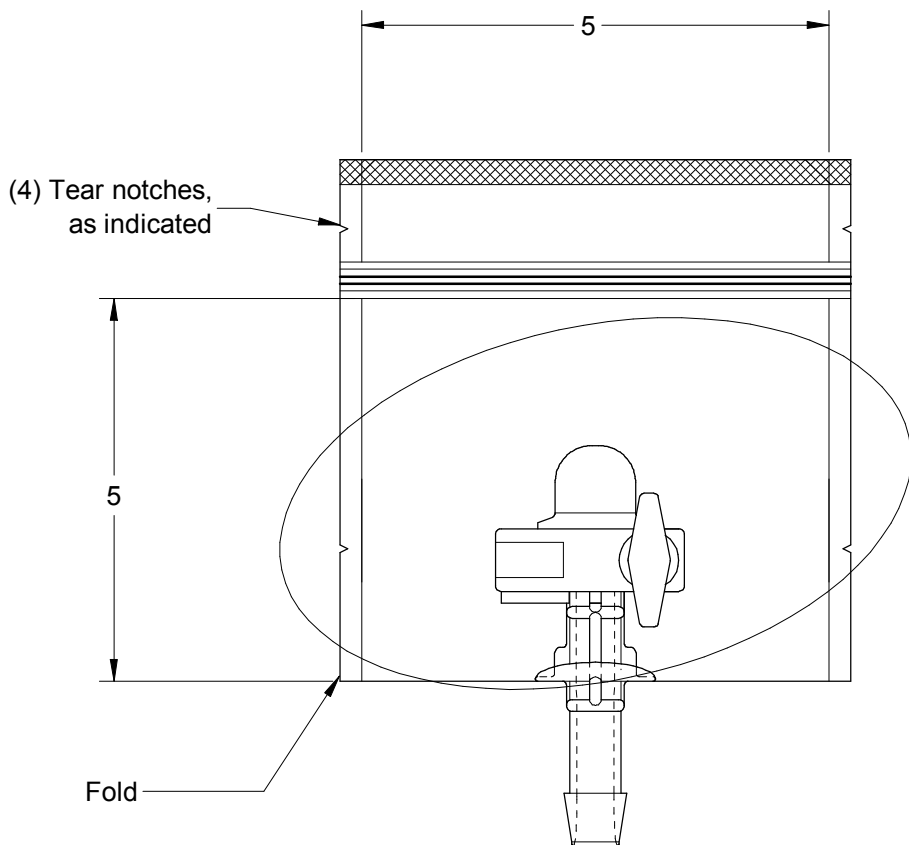

- NOTES:
 1) NO CONTAMINATION PERMITTED
 2) NO PARTING LINE PERMITTING ON FLUID SEALING SURFACES
 3) PARTS MUST BE MOLDED AND ASSEMBLED IN A CLEANROOM ENVIRONMENT

| TABLE A | |
|---------------|-----------------------|
| Part Number | Description |
| 2A-408-TC-5X5 | 1/4" HB x Mini Flange |
| 2A-608-TC-5X5 | 3/8" HB x Mini Flange |
| 2A-812-TC-5X5 | 1/2" HB x Mini Flange |

| | | | | | | |
|--|--------------------|---------------------|-----|-----------------|-------|--------------------|
| DRAWN BY B. Willemstyn | DATE 4-Mar-2010 | DWG NO 2A_sml.dc | REV | SHEET 1 OF 1 | SCALE | SHEET SIZE A |
| TITLE SterilEnz Assembly, Mini Flange 1/4", 3/8", 1/2" Hose Barb | | | | | | A |

| UNLESS OTHERWISE SPECIFIED: | |
|--|---|
| 1. ALL DIMENSIONS ARE IN INCHES 2. DO NOT SCALE DRAWING 3. REMOVE ALL BURRS AND SHARP EDGES TO .015 MAX. 4. MACHINED SURFACE TO BE 125 MICRO-INCHES | 5. TOLERANCES ON: XX DECIMALS %%P.02 XXX DECIMALS %%P.005 ANGLES %%P1%%D |

THIS DRAWING AND THE INFORMATION CONTAINED HEREIN ARE CONFIDENTIAL AND PROPRIETARY TO PAW BIOSCIENCE AND ARE TO BE USED ONLY FOR PURPOSES FOR WHICH THEY ARE FURNISHED AND ARE NOT TO BE COPIED, REPRODUCED, DUPLICATED, OR DISCLOSED TO OTHERS IN WHOLE OR IN PART WITHOUT THE PRIOR WRITTEN CONSENT OF PAW BIOSCIENCE, INC.



PAW BioScience Products

4

3

2

1