

4

3

2

1

REVISIONS INDICATED BY ▲			
REV	DATE	DCR#	TITLE

D

D

C

C

B

B

A

A

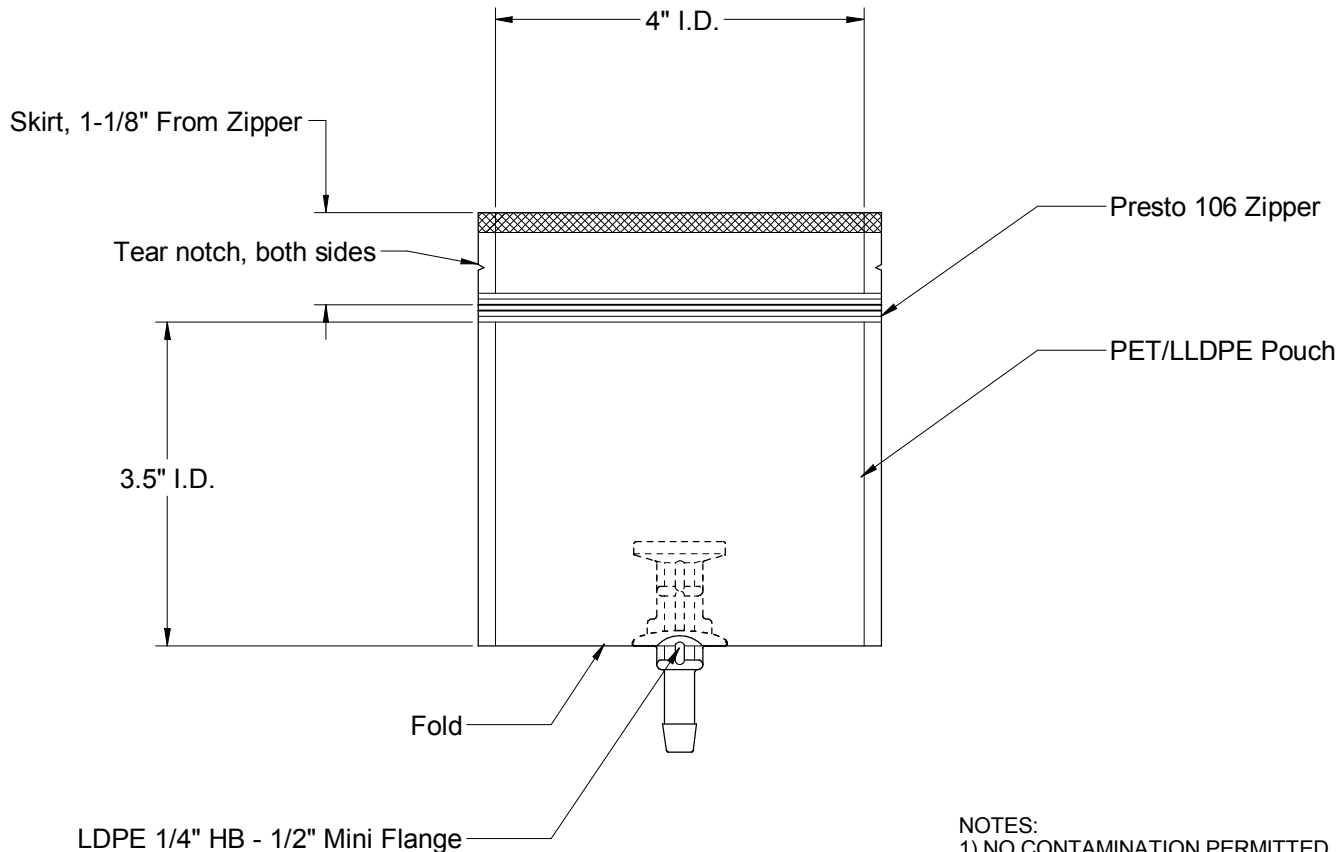

- NOTES:
 1) NO CONTAMINATION PERMITTED
 2) NO PARTING LINE PERMITTING ON FLUID SEALING SURFACES
 3) PARTS MUST BE MOLDED AND ASSEMBLED IN A CLEANROOM ENVIRONMENT

DRAWN BY B. Willemstyn	DATE Dec 2, 2005	DWG NO MPS_DS.25.75.dc	REV	SHEET 1 OF 1	SCALE
---------------------------	---------------------	---------------------------	-----	-----------------	-------

TITLE SterilEnz, 1/4" HB - 1/2" Mini Flange Part Number DS-408-TC-4X4					SHEET SIZE A
---	--	--	--	--	---------------------------

UNLESS OTHERWISE SPECIFIED:	
1. ALL DIMENSIONS ARE IN INCHES	5. TOLERANCES ON: XX DECIMALS %P.02 XXX DECIMALS %P.005 ANGLES %P1%1%D
2. DO NOT SCALE DRAWING	
3. REMOVE ALL BURRS AND SHARP EDGES TO .015 MAX.	
4. MACHINED SURFACE TO BE 125 MICRO-INCHES	

THIS DRAWING AND THE INFORMATION CONTAINED HEREIN ARE CONFIDENTIAL AND PROPRIETARY TO PAWBIO SCIENCE AND ARE TO BE USED ONLY FOR PURPOSES FOR WHICH THEY ARE FURNISHED AND ARE NOT TO BE COPIED, REPRODUCED, DUPLICATED, OR DISCLOSED TO OTHERS IN WHOLE OR IN PART WITHOUT THE PRIOR WRITTEN CONSENT OF PAWBIO SCIENCE, INC.



PAW BioScience Products

4

3

2

1